

THIS DRAWING IS UNPUBLISHED. RELEASED FOR PUBLICATION  
 © COPYRIGHT 2006 By - ALL RIGHTS RESERVED.

| LOC | DIST | REVISIONS   |                           |         |        |
|-----|------|-------------|---------------------------|---------|--------|
| P   | LTR  | DESCRIPTION | DATE                      | DWN     | APVD   |
| GP  | 00   | A1          | REVISED PER ECO-11-004835 | 11MAR11 | RK HMR |

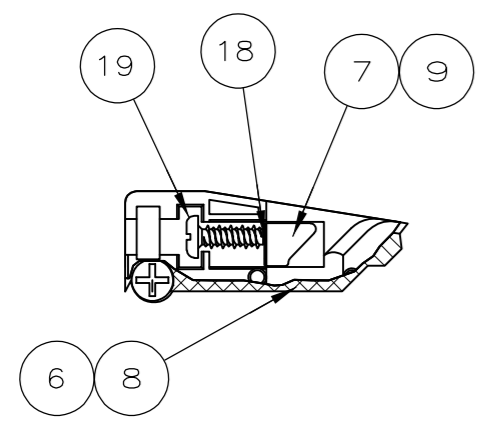

DETAIL A  
FOR -1 & 2 ONLY

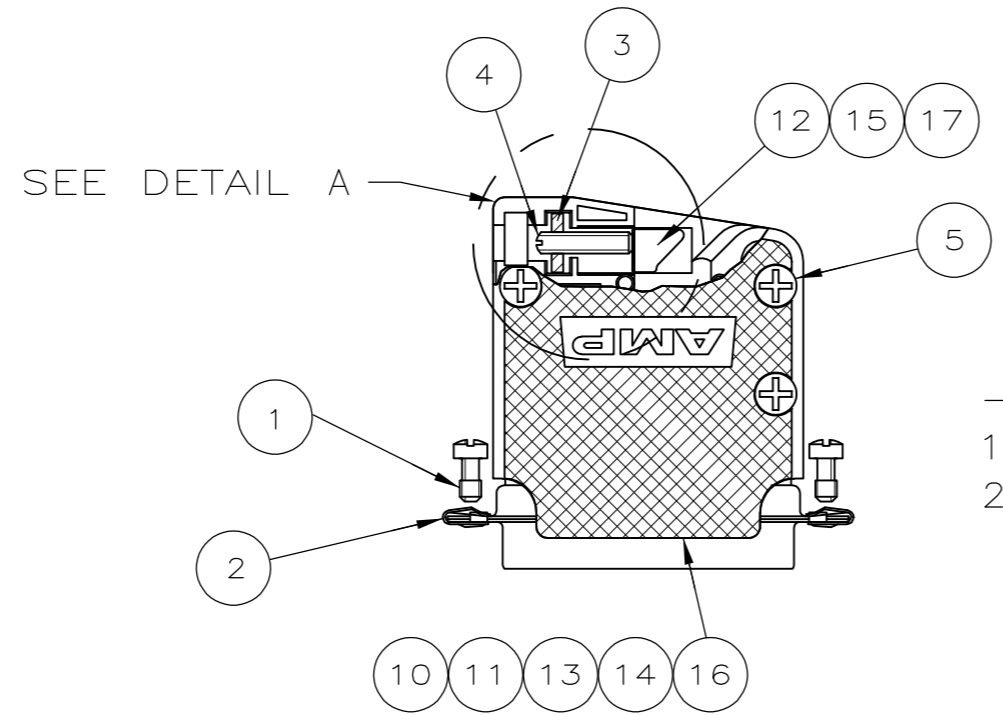

-3, -4, -5,  
1--1, 1--2,  
2--2 & 2--6

- 1 PARTS PACKAGED UNASSEMBLED.
- ② STAINLESS STEEL.
- ③ ZINC PLATED YELLOW CHROMATE COATING.
- ④ STEEL.
- ⑤ ZINC PLATED CLEAR CHROMATE COATING.
- ⑥ BRASS.
- ⑦ BLACK ZINC PHOSPHATE.
- ⑧ OBSOLETE.

|   |   |   |   |   |   |   |   | CONTENTS BULK PACKAGED BY ITEM         |     |    |
|---|---|---|---|---|---|---|---|--|-----|----|
|   |   |   |   |   |   |   |   | CONTENTS PACKAGED ONE KIT PER POLY BAG |     |    |
| - | - | - | - | - | - | 1 | 1 | GATE SCREW                             | ④ ⑦ | 19 |
| - | - | - | - | - | - | 1 | 1 | SHIM                                   | ⑥   | 18 |
| - | - | - | 1 | - | - | - | - | SIZE 5 GATE                            |     | 17 |
| - | - | - | 1 | - | - | - | - | SIZE 5 HOUSING                         |     | 16 |
| - | - | - | - | 1 | - | - | - | SIZE 4 GATE                            |     | 15 |
| - | - | - | - | 1 | - | - | - | SIZE 4 HOUSING                         |     | 14 |
| 1 | - | 1 | - | - | - | - | - | SIZE 3 SHORT HOUSING                   |     | 13 |
| 1 | 1 | 1 | - | - | 1 | - | - | SIZE 3 GATE                            |     | 12 |
| - | 1 | - | - | - | 1 | - | - | SIZE 3 HOUSING                         |     | 11 |
| - | - | - | 1 | - | - | - | - | SIZE 2 SHORT HOUSING                   |     | 10 |
| - | - | - | 1 | - | - | 1 | - | SIZE 2 GATE                            |     | 9  |
| - | - | - | - | - | - | 1 | - | SIZE 2 HOUSING                         |     | 8  |
| - | - | - | - | - | - | - | 1 | SIZE 1 GATE                            |     | 7  |
| - | - | - | - | - | - | - | 1 | SIZE 1 HOUSING                         |     | 6  |
| 2 | 3 | 2 | 3 | 3 | 3 | 2 | 1 | PH HD #5-21 HI-LO SCREW                | ④ ⑤ | 5  |
| 1 | 1 | 1 | - | 1 | 1 | 1 | - | SLOTTED SET SCREW                      | ④ ⑤ | 4  |
| 1 | 1 | 1 | - | 1 | 1 | 1 | - | SQUARE NUT                             | ④   | 3  |
| 2 | 2 | 2 | 2 | 2 | 2 | 2 | 2 | CLIP                                   | ②   | 2  |
| 2 | 2 | 2 | 2 | 2 | 2 | 2 | 2 | RETAINING SCREW                        | ③ ④ | 1  |

|  |     |                                 |   |                         |     |       |     |       |     |       |     |        |     |                   |            |  |
|--|-----|---------------------------------|---|-------------------------|-----|-------|-----|-------|-----|-------|-----|--------|-----|-------------------|------------|--|
| THIS DRAWING IS A CONTROLLED DOCUMENT.   |     | DWN<br>R.RICHARDSON<br>12SEPT05 |   |                         |     |       |     |       |     |       |     |        |     |                   |            |  |
| DIMENSIONS: INCHES   |     | CHK<br>C.ROHDE<br>12SEPT05      |   |                         |     |       |     |       |     |       |     |        |     |                   |            |  |
| TOLERANCES UNLESS OTHERWISE SPECIFIED:   |     | APVD<br>M.WALMSLEY<br>12SEPT05  | NAME<br>STRAIN RELIEF KIT, 45 /180<br>AMPLIMITE HD-20 |                         |     |       |     |       |     |       |     |        |     |                   |            |  |
| <table border="1"> <tr><td>0 PLC</td><td>± -</td></tr> <tr><td>1 PLC</td><td>± -</td></tr> <tr><td>2 PLC</td><td>± -</td></tr> <tr><td>3 PLC</td><td>± -</td></tr> <tr><td>4 PLC</td><td>± -</td></tr> <tr><td>ANGLES</td><td>± -</td></tr> </table> |     | 0 PLC                           | ± -   | 1 PLC                   | ± - | 2 PLC | ± - | 3 PLC | ± - | 4 PLC | ± - | ANGLES | ± - | PRODUCT SPEC<br>- | SIZE<br>A2 |  |
| 0 PLC  | ± - |                                 |   |                         |     |       |     |       |     |       |     |        |     |                   |            |  |
| 1 PLC  | ± - |                                 |   |                         |     |       |     |       |     |       |     |        |     |                   |            |  |
| 2 PLC  | ± - |                                 |   |                         |     |       |     |       |     |       |     |        |     |                   |            |  |
| 3 PLC  | ± - |                                 |   |                         |     |       |     |       |     |       |     |        |     |                   |            |  |
| 4 PLC  | ± - |                                 |   |                         |     |       |     |       |     |       |     |        |     |                   |            |  |
| ANGLES   | ± - |                                 |   |                         |     |       |     |       |     |       |     |        |     |                   |            |  |
| MATERIAL HOUSING & GATES: POLYPROPYLENE<br>HARDWARE: ② ④ ⑥   |     | APPLICATION SPEC<br>-           | CAGE CODE<br>00779                                    | DRAWING NO<br>C=5206478 |     |       |     |       |     |       |     |        |     |                   |            |  |
| FINISH HOUSING & GATES: BLACK<br>HARDWARE: ③ ⑤ ⑦   |     | WEIGHT<br>-                     | RESTRICTED TO<br>-                                    | SCALE<br>2:1            |     |       |     |       |     |       |     |        |     |                   |            |  |
| CUSTOMER DRAWING   |     | SHEET 1 of 1                    |   | REV A1                  |     |       |     |       |     |       |     |        |     |                   |            |  |